

100 Kg

SD Card real time recorder

10 ms sampling time recorder

FORCE GAUGE

Model : FG-6100SD



Your purchase of this FORCE GAUGE marks a step forward for you into the field of precision measurement. Although this FORCE GAUGE is a complex and delicate instrument, its durable structure will allow many years of use if proper operating techniques are developed. Please read the following instructions carefully and always keep this manual within easy reach.



OPERATION MANUAL

TABLE OF CONTENTS

1	FEATURES.....	1
2	SPECIFICATIONS.....	2
3	FRONT PANEL DESCRIPTIONS	6
	3-1 Sensor Input socket.....	6
	3-2 LCD Display.....	6
	3-3 Power/BACKLIGHT Button.....	6
	3-4 ▲/ZERO Button.....	6
	3-5 FAST/SLOW/ESC Button.....	6
	3-6 PEAK/ENTER Button.....	6
	3-7 DISPLAY REVERSE/▼ Button.....	6
	3-8 TIME/SET Button.....	6
	3-9 LOGGER/SAMPLING CHECK Button.....	6
	3-10 RS-232 output terminal.....	6
	3-11 Reset terminal.....	6
	3-12 DC 9V Power Adapter Input Socket.....	6
	3-13 SD card socket.....	6
	3-14 Battery Cover/Compartment.....	6
	3-15 Sensor Hooks.....	6
	3-16 Sensor (force sensor).....	6
	3-17 Sensor plug.....	6
4	MEASURING PROCEDURE	8
	4-1 Pay attention for the measurement.....	8
	4-2 Normal Measurement	9
	4-3 Peak Hold Measurement	10
	4-4 LCD Back light On/Off.....	11
	4-5 Alarm beeper.....	11

5. DATALOGGER.....	11
5-1 Preparation before execute datalogger function.....	11
5-2 Normal record mode	
Auto Datalogger (Set sampling time \geq 1 second).....	12
5-3 Normal record mode	
Manual Datalogger (Set sampling time = 0 second).....	13
5-4 Peak hold record mode	
Fast Datalogger.....	14
5-5 Check time information.....	15
5-6 Check sampling time information.....	15
5-7 SD Card Data structure.....	15
6. Saving data from the SD card to the computer.....	17
7. ADVANCED SETTING.....	19
8. POWER SUPPLY from DC ADAPTER.....	25
9. BATTERY REPLACEMENT.....	25
10. SYSTEM RESET.....	25
11. RS232 PC SERIAL INTERFACE.....	26
12. APPLICATIONS.....	27

1. FEATURES

- * Data record mode : Normal model or Peak hold mode.
- * Normal record mode :
Set sampling time from 1 second to 8 hours.
- * Peak hold record mode :
Set sampling time from 10 ms to 500 ms.
- * Memory capacity of normal record mode : 1 GB to 16 GB.
- * Memory capacity of peak hold record mode :
1000 data no. (max.)
- * Under Peak hold record mode, if execute the " Data record " function, the memory circuit will store 1000 data no. (max.) measuring data into the SD card per fast speed sampling time (10 ms to 500 ms).
- * Under Normal record mode, if execute the " Data record " function, will save the measuring data along the real time value (Year/Month/ Date/Hour/Minute/Second) into the SD card per normal sampling time (1 second to 8 hours).
- * After save the data into the SD memory card, it can be down load the data to the Excel directly, extra software is no need. User can make the further data analysis (graphic analysis) by themselves.
- * Large LCD display with back light.
- * 100 Kg, wide capacity, high resolution, high accuracy, high repeatability.
- * 3 kind display unit : Kg, lb, Newton.
- * Tension & compression capability .
- * Peak hold (Max. load) can be held in display during make tension or compression measurement.
- * Zero button can operate both for normal measuring & the " peak hold " operation.
- * Full capacity zero (tare) control capability.
- * Fast/Slow response time push button.

- * Positive or reverse display direction select.
- * Hand held & stand mounted gauges are available.
- * Low power consumption gives long battery life.
- * Build in low battery indicator.
- * Microprocessor circuit & exclusive load cell transducer.
- * Over load protection.
- * RS-232 computer interface
- * Built-in DC 9V power adapter input socket.
- * Professional test stand (optional).

2. SPECIFICATIONS

Display	LCD (Liquid crystal display). 5 digits, 16 mm (0.63") digit size. Back light.
Display Direction	Positive or Reverse direction, select by the push button on the front panel.
Function	Tension & Compression (Push & Pull). Normal force, Peak hold (Max. load).
Peak hold	Will freeze the display value of the Peak load (Max. load).
Zero	Zero button can be operated both for "normal force" or "peak hold" operation
Unit select	Kg, lb, Newton.
Measure Capacity	100 Kg/220.5 lb/980.6 Newton.
Resolution	0.02 Kg/0.02 lb/0.2 Newton.
Min. Display	0.15 Kg/0.35 lb/1.4 Newton.
Accuracy	$\pm (0.5 \% + 0.1 \text{ Kg})$, within $23 \pm 5^{\circ}\text{C}$. <i>* Under the test weight on 100 Kg & 10 Kg.</i>

Update time	Fast Approx. 0.2 second. Slow Approx. 0.6 second.
Over range Indicator	Display show " - - - - " when in over range status.
Normal data record mode	Auto data logger 1 sec to 8 hour 59 min. 59 sec. @ Sampling time can set to 1 second, but memory data may loss.
Sampling Time Setting range	Manual data logger Push the data logger button once will save data one time. @ Set the sampling time to 0 second. @ Manual mode, can also select the 1 to 99 position (Location) no.
Peak hold data record mode Sampling Time Setting range	10 mS to 500 mS. * Each setting step is 10 mS. * Auto data logger * The memory circuit will store 1000 data no. (max.) measuring data.
Data error no.	≤ 0.1% of total saved data max.
Memory Card	SD memory card. 1 GB to 16 GB.
Advanced setting	* SD memory card Format * Set clock time (Year/Month/Date, Hour/Minute/Second) * Set sampling time (normal data record mode) * Set sampling time (peak hold data record mode) * Auto power OFF management * Unit setting * Set beep Sound ON/OFF * Decimal point of SD card setting
Data output	RS 232/USB PC computer interface. * Connect the optional RS232 cable UPCB-02 will get the RS232 plug. * Connect the optional USB cable USB-01 will get the USB plug.

Overload Capacity	Max. 150 kg.
Full Scale Deflection	Less than 1 mm.
Zero/tare Control	Max. full capacity.
Sensor type	S type load cell.
Circuit	Exclusive microprocessor LSI-circuit.
Power Supply	*.Alkaline or heavy duty DC 1.5 V battery (UM3, AA) x 6 PCs, or equivalent.
	*.DC 9V adapter input. (AC/DC power adapter is optional).
Power Current	Normal operation (w/o SD card save data and LCD Backlight is OFF) : <i>Approx. DC 12 mA.</i>
	When SD card save the data and LCD Backlight is OFF) : <i>Approx. DC 38 mA.</i>
	*.If LCD backlight on, the power consumption will increase approx. 4 mA.
Operating Temperature	0°C to 50°C (32°F to 122°F).
Operating Humidity	Less than 80% RH.
Dimension	<i>Main instrument :</i> 215 x 90 x 45 mm (8.5 x 3.5 x 1.8 inch). <i>Sensor with two hooks :</i> 162 x 51 x 22 mm (6.4 x 2.0 x 0.9 inch) <i>Cable length :</i> 2 meters.
Weight	<i>Main instrument :</i> 288 g (0.63 LB) @ meter only <i>Sensor :</i> 635 g (1.40 LB)

Accessories Included	Operating manual 1 PC. 100 Kg sensor with 2 hooks and 2 meter cable..... 1 PC. Carrying case 1 PC.
Optional Accessories	* SD memory card (4 GB) * RS232 cable, Model : UPCB-02. * USB cable, Model : USB-01 * Software for data logging & data recorder. Model : SW-U801-WIN. * EXCEL data acquisition software Model : SW-E802

3. FRONT PANEL DESCRIPTIONS

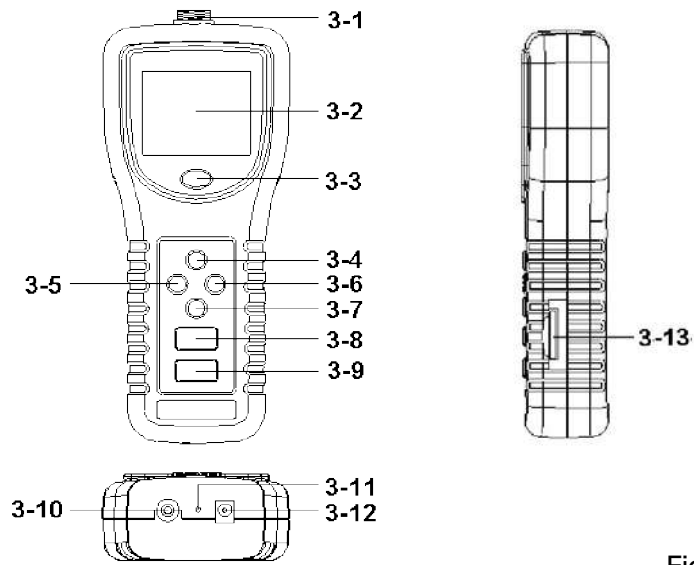
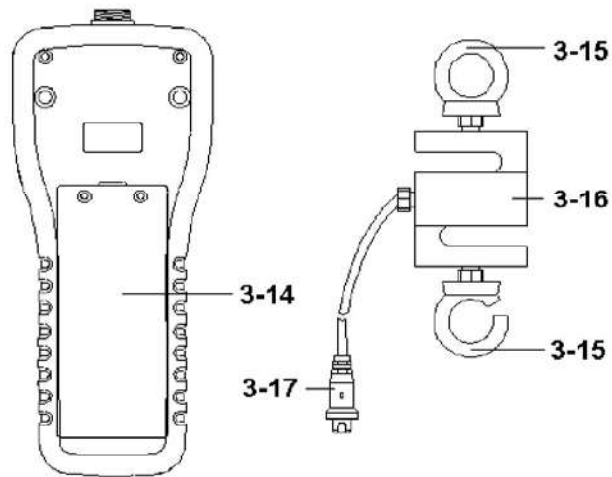

Fig. 1



- 3-1 Sensor Input socket
- 3-2 LCD Display
- 3-3 Power/BACKLIGHT Button
- 3-4 ▲/ZERO Button
- 3-5 Fast/SLOW/ESC Button
- 3-6 PEAK/ENTER Button
- 3-7 DISPLAY REVERSE/▼ Button
- 3-8 TIME/SET Button
- 3-9 LOGGER/SAMPLING CHECK Button
- 3-10 RS-232 output terminal
- 3-11 Reset terminal
- 3-12 DC 9V Power Adapter Input Socket
- 3-13 SD card socket
- 3-14 Battery Cover/Compartment
- 3-15 Sensor Hooks
- 3-16 Sensor (force sensor)
- 3-17 Sensor plug

4. MEASURING PROCEDURE

4-1 Pay attention for the measurement

- 1) Compression measurement, the display will show the " - " mark automatically.

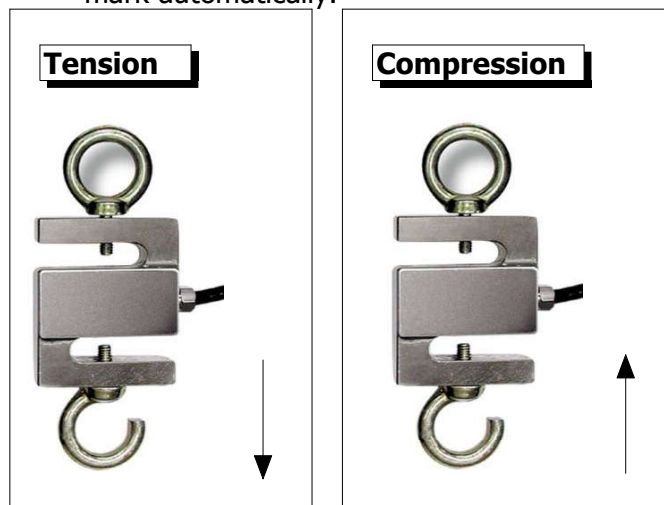

- 2) During the measurement, the SENSING HEAD along the adapter has to be on a line with measuring object.
(ref. Fig. 2)

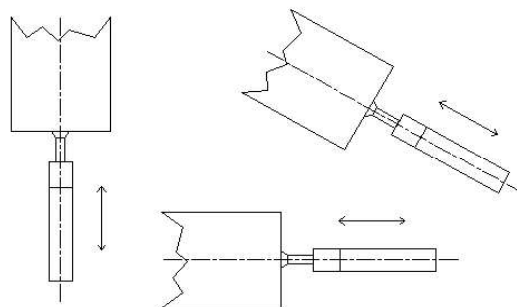

Fig. 2

- 3) Rotate the SENSING HEAD is prohibited. Some certain angles between SENSING HEAD & measuring object are not allowed.

4-2 Normal Measurement

1) *Power on/off*

Power on :

Press " Power Button " (3-3, Fig. 1) once.

Power off :

During power on, press " Power Button " (3-3 , Fig. 1) > 2 seconds. will power off.

- 2) Determine display unit of Kg, lb or Newton by selecting the unit at first with default, refer to chapter 7 " ADVANCED SETTING ".
- 3)* Insert the " Sensor Plug " (3-17, Fig. 1) to " Sensor Input socket " (3-1, Fig. 1)
- * Connect " Sensor " (3-16, Fig. 1) with the " Measuring Object " via the " Sensor hook " (3-15, Fig. 1) in straight line.
- 4)" Zero Adjust " by pushing " Zero Button " (3-4, Fig. 1) before every measurement.

5) Start measurement by giving force (push or pull), then the LCD will display the Average reading value.

Note :

** During the measurement, if intend to change the display direction, just push the " Reverse Button " (3-7, Fig. 1) once.*

* There are two kind sampling time of display, FAST and SLOW. Push the " FAST/SLOW Button " once in sequence (3-5, Fig. 1), if the upper left corner of LCD show " FAST " indicator , then the display reading is under the operation of fast sampling time measurement. If the LCD show " SLOW " indicator, the display reading is under the slow sampling time measurement.

* Over range display of tension function, LCD will show " ----- "

* Over range display of compression function, LCD will show " ----- "

4-3 Peak Hold Measurement

The meter can measure the peak value of force both of tension & compression operation. The operation procedures of Peak Hold Measurement are same as above " 4-2 Normal Measurement " but should press the " PEAK Button " (3-6, Fig. 1) once, the Display will show the " PEAK " indicator, then during the measurement the Display will freeze on the Peak hold value.

4-4 LCD Back Light On/Off

During the measurement, press the " BACKLIGHT Button " (3-3, Fig. 1) once the LCD Back Light will be ON. During the LCD Back Light ON, press the " BACKLIGHT Button " once again, the LCD Back Light will be OFF again.

4-5 Alarm beeper

If the measuring value over the 100.00 Kg, the internal buzzer will sound for warning.

5. DATALOGGER

5-1 Preparation before execute datalogger function

a. Insert the SD card

** It recommend use memory card \leq 4 GB.*

Prepare a " SD memory card " (1 GB to 16 GB, optional), insert the SD card into the " SD card socket " (3-13, Fig. 1).

** When plug in the SD card, the up side of the SD card should face against the down case.*

b. SD card Format

If SD card just the first time use into the meter, it recommend to make the " SD card Format " at first. , please refer chapter 7-1, page 20.

** It recommend strongly, do not use memory cards that have been formatted by other meter or by other installation (such as camera...).*

Reformat the memory card with your meter.

** If the SD memory card exist the trouble during format by the meter, use the Computer to reformat again can fix the problem.*

c. Time setting

If the meter is used at first time, it should to adjust the clock time exactly, please refer chapter 7-2, page 20.

d. Decimal format setting



The numerical data structure of SD card is default used the "." as the decimal, for example "20.6" "1000.53". But in certain countries (Europe ...) is used the ",", as the decimal point, for example " 20, 6 " "1000,53". Under such situation, it should change the Decimal character at first, details of setting the Decimal point, refer to Chapter 7-8, page 24.

5-2 Normal record mode

Auto Datalogger (Set sampling time \geq 1 second)

a. Start the datalogger

Press the " LOGGER Button (3-9, Fig. 1) > 2 seconds continuously , the LCD will show the indicator " DATA RECORD " with flashing, at the same time the measuring data along the time information will be saved into the memory circuit.

Remark :

- * How to set the sampling time, refer to Chapter 7-3 page 21.*
- * How to set the beeper sound is enable, refer to Chapter 7-6, page 23.*

b. Pause the datalogger

During execute the Datalogger function , if press the " Logger Button " (3-9, Fig. 1) once will pause the Datalogger function (stop to save the measuring data into the memory circuit temporally). In the same time the indicator of " DATA RECORD " will stop to flash..

Remark :

If press the " Logger Button " (3-9, Fig. 1) once again will execute the Datalogger again, the bottom text of DATA RECORD " will flashing .

c. Finish the Datalogger

During pause the Datalogger (or pause the Datalogger), Press the " LOGGER Button (3-9, Fig. 1) > 2 seconds continuously, the " DATA RECORD " indicator will be disappeared and finish the Datalogger.

5-3 Normal record mode

Manual Datalogger (Set sampling time = 0 second)

a. Set sampling time is to 0 second

Press the " LOGGER Button (3-9, Fig. 1) > 2 seconds continuously, the LCD will show the indicator " DATA RECORD " (not flashing). Press the " Logger Button " (3-9, Fig. 1) once, the " DATA RECORD " indicator will flash once a while and Beeper will sound once, at the same time the measuring data along the time information will be saved into the memory circuit. The lower Display will show the Position (Location) no. and saved into the SD card too.

Remark :

During execute the Manual Datalogger, press the " ▲ Button " (3-4, Fig. 1) or " ▼ Button " (3-7, Fig. 1) to set the measuring Location no. (1 to 99, for example room 1 to room 99) to identify the measurement location , the lower Display will show P x (x = 1 to 99).

b. Finish the Datalogger

Press the " LOGGER Button (3-9, Fig. 1) > 2 seconds continuously, the " DATA RECORD " indicator will be disappeared and finish the Datalogger.

**5-4 Peak hold record mode
(Fast Datalogger)**

- 1) Recommend the Force gauge install to the Test stand (such as FS-1001, FS-1002..), Power on the meter.
 - 2) Press the " PEAK Button " (3-6, Fig. 1) once, the Display will the indicator " PEAK " and " FAST ".
 - 3) Press the " Zero Button " (3-4, Fig. 1) once, the Display will set to " ZERO " value.
 - 4)* Press the " LOGGER Button (3-9, Fig. 1) once , the LCD will show the indicator " DATA RECORD " at the same time the sampling time value in ms (milli seconds) will appear a while in the bottom LCD, for example " 10 ". Now the meter is ready for the " Peak hold record mode (Fast Datalogger measurement) ".
- * If apply the force value (tension/compression) > 1.00 Kg (1% full capacity), then the measurement value according the sampling period will save to the internal memory circuit in sequence.

Remark :

** How to set the sampling time, refer to Chapter 7-4 page 22.*

- * When the peak value is got, the LCD indicator " DATA RECORD " will be disappeared . The indicator will show " PEAK " indicator only, in the same time the peak value will freeze on the Display
- * Following the bottom LCD will show the data record no. and count down to zero, in the same time all the memory data will save into the SD memory card.

5-5 Check the time information

During the normal measurement screen (not execute the Datalogger),

- 1)If press " Time Button " (3-8, Fig. 1) once , the lower LCD display will present the time information of Hour/Minute/Second (h.m.s) in the lower Display.
- 2)If press " Time Button " (3-8, Fig. 1) once again , the lower LCD display will present the time information of Year/Month/Date (yy.mm.dd) in the lower Display.
- 3)If press " Time Button " (3-8, Fig. 1) once again , the LCD will return to normal screen.

5-6 Check sampling time information

During the normal measurement screen (not execute the Datalogger), If press " Sampling Button " (3-9, Fig. 1) once , the lower LCD display will present the Sampling time information in second unit.

5-7 SD Card Data structure

- 1)When the first time, the SD card is used into the meter, the SD card will generate a route :

FGC01

- 2) If the first time to execute the Datalogger, under the route FGC01\, will generate a new file name FGC01001.XLS. After exist the Datalogger, then execute again, the data will save to the FGC01001.XLS until Data column reach to 30,000 columns, then will generate a new file, for example FGC01002.XLS
- 3) Under the folder FGC01\, if the total files more than 99 files, will generate anew route, such as FGC02\

4) The file's route structure :

```

FGC01\
  FGC01001.XLS
  FGC01002.XLS
  .....
  FGC01099.XLS

```

```

FGC02\
  FGC02001.XLS
  FGC02002.XLS
  .....
  FGC02099.XLS

```

```

FGCXX\
  .....
  .....

```

Remark :
XX : Max. value is 10.

6. Saving data from the SD card to the computer (EXCEL software)

- 1) After execute the Data Logger function, take away the SD card out from the " SD card socket " (3-20, Fig. 1).
- 2) Plug in the SD card into the Computer's SD card slot (if your computer build in this installation) or insert the SD card into the " SD card adapter ". then connect the " SD card adapter " into the computer.
- 3) Power ON the computer and run the " EXCEL software ".
 Download the saving data file (for example the file name : FGC01001.XLS, FGC01002.XLS) from the SD card to the computer. The saving data will present into the EXCEL software screen (for example as following EXCEL data screens) , then user can use those EXCEL data to make the further Data or Graphic analysis usefully.

EXCEL data screen (for example, normal record mode)

	A	B	C	D	E
1	Position	Date	Time	Ch1_Value	Ch1_Unit
2	5287	2011/1/3	15:13:04	45.02	Kg
3	5288	2011/1/3	15:13:05	45.02	Kg
4	5289	2011/1/3	15:13:07	45.06	Kg
5	5290	2011/1/3	15:13:09	45.36	Kg
6	5291	2011/1/3	15:13:11	45.12	Kg
7	5292	2011/1/3	15:13:13	45.3	Kg
8	5293	2011/1/3	15:13:15	45.24	Kg
9	5294	2011/1/3	15:13:17	45.2	Kg
10	5295	2011/1/3	15:13:19	45.18	Kg
11	5296	2011/1/3	15:13:21	45.22	Kg
12	5297	2011/1/3	15:13:23	45.32	Kg
13	5298	2011/1/3	15:13:25	45.22	Kg

EXCEL data screen (for example, peak hold record mode)

	PeakHold	Chn_Value	Unit	SampleTim	Start Date	Start Time
19	P0000	-1.38	Kg	20mS	2011/1/3	15:13:56
20	P0001	-1.38	Kg			
21	P0002	-5.68	Kg			
22	P0003	-5.68	Kg			
23	P0004	-6.98	Kg			
24	P0005	-7.54	Kg			
25	P0006	-7.54	Kg			
26	P0007	-8.24	Kg			
27	P0008	-8.92	Kg			
28	P0009	-9	Kg			
29	P0010	-9.66	Kg			
30	P0011	-11.1	Kg			
31	P0012	-12.4	Kg			

EXCEL graphic screen (for example, graphic 1)

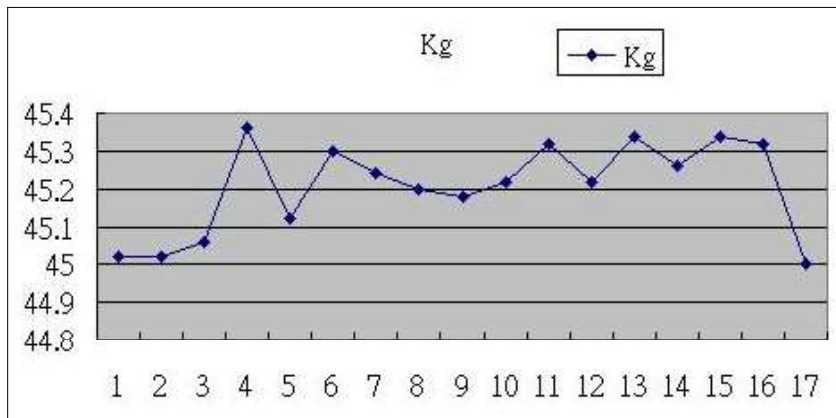

EXCEL graphic screen (for example, graphic 2)

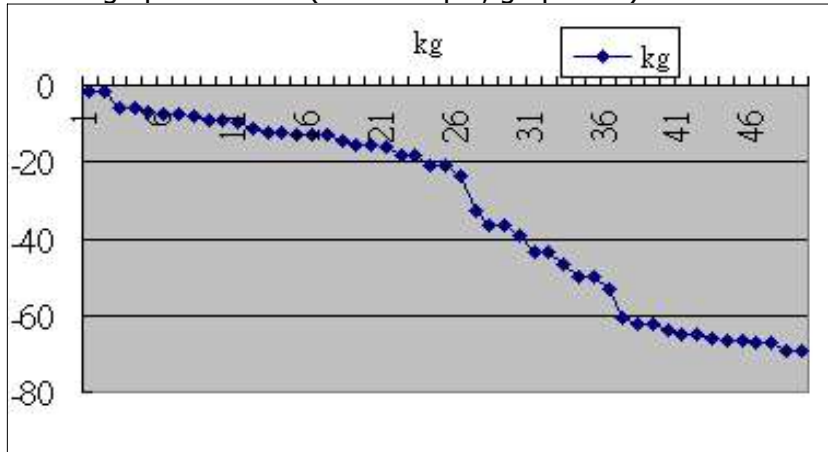

7. ADVANCED SETTING

Under do not execute the Datalogger function, press the " SET Button " (3-8, Fig. 1) continuously at least two seconds will enter the " Advanced Setting " mode. then press the " SET Button " (3-8, Fig. 1) once a while in sequence to select the eight main function, the display will show :

- Sd F.....** SD memory card Format
- dAtE.....**Set clock time (Year/Month/Date, Hour/Minute/Second)
- SP-t.....**Set sampling time for normal record mode
- HSPt.....**Set sampling time for peak record mode
- PoFF.....**Auto power OFF management
- bEEP.....**Set beeper sound ON/OFF
- unit.....**Set the measurement unit
- dEC.....**Set SD card Decimal character
- ESC.....** Escape from the advanced setting

Remark :

During execute the " Advanced Setting " function, if press " ESC Button " (3-5, Fig. 1) will exit the " Advanced Setting " function, the LCD will return to normal screen.

7-1 SD memory card Format

When the lower display show " Sd F "

- 1) Use the " ▲ Button " (3-4, Fig. 1) or " ▼ Button " (3-7, Fig. 1) to select the upper value to " yES " or " no ".

yES - Intend to format the SD memory card
no - Not execute the SD memory card format

- 2) If select the upper to " yES ", press the " Enter Button " (3-6, Fig. 1) once again, the Display will show text " yES Enter " to confirm again, if make sure to do the SD memory card format, then press " Enter Button " once will format the SD memory clear all the existing data that already saving into the SD card.

7-2 Set clock time (Year/Month/Date, Hour/Minute/ Second)

When the upper display show " dAtE "

- 1) Use the " ▲ Button " (3-4, Fig. 1) or " ▼ Button " (3-7, Fig. 1) to adjust the value (Setting start from Year value). After the desired value is set, press the " Enter Button " (3-6, Fig. 1) once will going to next value adjustment (for example, first setting value is Year then next to adjust Month, Date, Hour, Minute, Second value).

Remark : The adjusted value will be flashed.

- 2) After set all the time value (Year, Month, Date, Hour, Minute, Second), press the " SET Button " (3-8, Fig. 1) once will save the time value, then the screen will jump to " Sampling time " setting screen (Chapter 7-3).

Remark :

After the time value is setting, the internal clock will run precisely even Power off if the battery is under normal condition (No low battery power).

7-3 Set sampling time (normal record mode)

When the upper display show " SP-t "

- 1) Use the " ▲ Button " (3-4, Fig. 1) or " ▼ Button " (3-7, Fig. 1) to adjust the value (Setting start from Hour value). After the desired value is set, press the " Enter Button " (3-6, Fig. 1) once will going to next value adjustment (for example, first setting value is Hour then next to adjust Minute, Second value).

Remark :

The adjusted value will be flashed.

- 2) After set all the sampling time value (Hour, Minute, Second), press the " SET Button " (3-8, Fig. 1) once will save the sampling value with default then the screen will jump to " Set sampling time for peak record mode " setting screen (Chapter 7-4).

7-4 Set sampling time for peak record mode

When the lower display show " HSPT "

- 1) Use the " ▲ Button " (3-4, Fig. 1) or " ▼ Button " (3-7, Fig. 1) to adjust the value (adjust unit is milli seconds, each step is 10 ms, setting start from 10 ms). After the desired value is set, press the " Enter Button " (3-6, Fig. 1) will save the setting value with default.

Remark :

The adjusted value range is from 10 ms to 500 ms,

- 2) After set the sampling time value, press the " SET Button " (3-6, Fig. 1) once the screen will jump to " Auto power OFF " setting screen (Chapter 7-5).

7-5 Auto power OFF management

When the lower display show " PoFF "

- 1) Use the " ▲ Button " (3-4, Fig. 1) or " ▼ Button " (3-7, Fig. 1) to select the upper value to " yES " or " no ".

yES - Auto Power Off management will enable.
no - Auto Power Off management will disable.

- 2) After select the upper text to " yES " or " no ", press the " Enter Button " (3-6, Fig. 1) will save the setting function with default.

7-6 Set beeper sound ON/OFF

When the lower display show " bEEP "

- 1) Use the " ▲ Button " (3-4, Fig. 1) or " ▼ Button " (3-7, Fig. 1) to select the upper value to " yES " or " no ".

yES - Meter's beep sound will be ON with default.
no - Meter's beep sound will be OFF with default.

- 2) After select the upper text to " yES " or " no ", press the " Enter Button " (3-6, Fig. 1) will save the setting function with default.

7-7 Set the measurement unit

When the lower display show " unit "

- 1) Use the " ▲ Button " (3-4, Fig. 1) or " ▼ Button " (3-7, Fig. 1) to select the measurement unit in " Kg ", " lb ", " N ", in the same time the upper LCD will show the full scale value for the corresponding measurement unit.

Remark :

Kg - Killo gram, full scale is 100.00 Kg

lb - Pound, full scale is 220.50 lb

N - Newton , full scale is 980.6 N

- 2) After select the measurement unit, press the " Enter Button " (3-6, Fig. 1) will save the setting function with default.

7-8 Decimal point of SD card setting

The numerical data structure of SD card is default used the "." as the decimal, for example "20.6" "1000.53". But in certain countries (Europe ...) is used the "," as the decimal point, for example " 20,6 " "1000,53". Under such situation, it should change the Decimal character at first.

When the lower display show " dEC "

- 1) Use the " ▲ Button " (3-4, Fig. 1) or " ▼ Button " (3-7, Fig. 1) to select the upper text to " bASIC " or " Euro ".

USA - Use "." as the Decimal point with default.

Euro - Use "," as the Decimal point with default.

- 2) After select the upper text to " USA " or " Euro ", press the " Enter Button " (3-6, Fig. 1) will save the setting function with default.

7-9 ESC

When the display show " ESC "

When the Display show the text " ESC ", then press the " SET Button " (3-8, Fig. 1) or " ESC Button " (3-5, Fig. 1) will finish the Advanced Setting procedures.

Remark :

During execute the " Advanced Setting " function, if press " ESC Button " (3-5, Fig. 1) will exit the " Advanced Setting " function, the LCD will return to normal screen.

8. POWER SUPPLY from DC ADAPTER

The meter also can supply the power supply from the DC 9V Power Adapter (optional). Insert the plug of Power Adapter into " DC 9V Power Adapter Input Socket " (3-12, Fig. 1). The meter will permanent power ON when use the DC ADAPTER power supply (The power Button function is disable).

9. BATTERY REPLACEMENT

- 1)When the left corner of LCD display show "  ", it is necessary to replace the battery. However, in-spec. measurement may still be made for several hours after low battery indicator appears before the instrument become inaccurate.
- 2)Loose the screws of the " Battery Cover " (3-14, Fig. 1) and take away the " Battery Cover " from the instrument and remove the battery.
- 3)Replace with DC 1.5 V battery (UM3, AA, Alkaline/heavy duty) x 6 PCs, and reinstate the cover.
- 4)Make sure the battery cover is secured after changing batteries.

10. SYSTEM RESET

If the meter happen the troubles such as :
CPU system is hold (for example, the key button can not be operated...).

Then make the system RESET will fix the problem.
The system RESET procedures will be either following method :

During the power on, use a pin to press the " Reset Button " (3-11, Fig. 1) once a while will reset the circuit system.

11. RS232 PC SERIAL INTERFACE

The instrument has RS232 PC serial interface via a 3.5 mm terminal (3-10, Fig. 1).

The data output is a 16 digit stream which can be utilized for user's specific application.

A RS232 lead with the following connection will be required to link the instrument with the PC serial port.

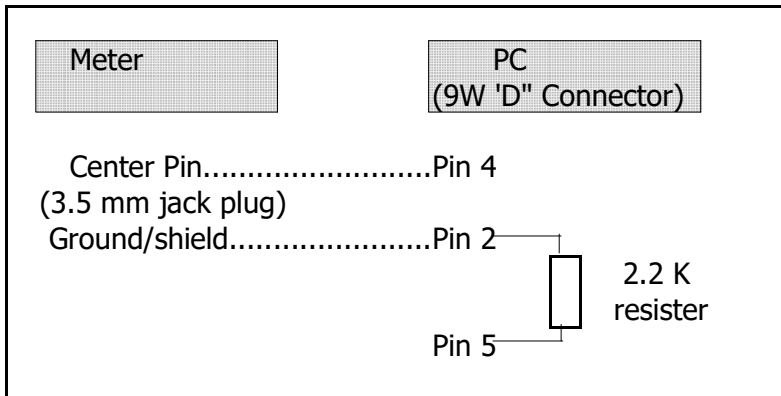

The 16 digits data stream will be displayed in the following format :

D15 D14 D13 D12 D11 D10 D9 D8 D7 D6 D5 D4 D3 D2 D1 D0

Each digit indicate the following status :

D15	Start Word		
D14	4		
D13	1		
D12 and D11	Anunuciator for Display		
	g = 57	Newton = 59	oz =58
	Kg = 55	LB = 56	

D10	Polarity 0 = Positive 1 = Negative
D9	Decimal Point(DP), position from right to the left 0 = No DP, 1= 1 DP, 2 = 2 DP, 3 = 3 DP
D8 to D1	Display reading, D1 = LSD, D8 = MSD <i>For example :</i> <i>If the display reading is 1234, then D8 to D1 is : 1234</i>
D0	End Word

RS232 FORMAT : 9600, N, 8, 1

Baud rate	9600
Parity	No parity
Data bit no.	8 Data bits
Stop bit	1 Stop bit

12. APPLICATIONS

12-1 Electronics

- * Test strength of solder points and spot welds on circuit boards.
- * Test wire wraps on clip connection.
- * Test pull strength of modified wire wrap connection on posts.
- * Test spring clip insertion and withdrawal forces.
- * Pull test welds in micro-electronic devices.
- * Measure torque, timing belt tension, sliding friction, etc., on computer peripheral equipment.
- * Test P.C. board insertion force.
- * Test insertion and withdrawal forces of various circuit components such as transistors and integrated circuits.
- * Test actuating force of snap action switches.

12-2 Business Equipment

- * Measure force required to perforate cards.
- * Measure load on slitter knives.
- * Measure actuating requirements of typewriter.
- * Test clutch release force.
- * Measure torque, timing belt tension (by deflection), sliding friction, etc., on computer peripheral equipment.
- * Test adhesion strength of labels and stickers.
- * Test load on paper thickness gages.
- * Measure tension of pencils.
- * Test actuating requirements on push buttons and flip switches.

12-3 Chemical & Plastics

- * Test film bond strengths.
- * Tensile test rubber, fibers and filaments.
- * Measure firmness of polyurethane foam.
- * Test crush strength of pills (medicine)
- * Test peel strength of adhesives.
- * measure compression of ceramic compounds.
- * Test vacuum take-down pressure on process machines.

12-4 Machinery & Manufacturing

- * Test load on wire feel
- * Test force to open cabinet doors.
- * Test sprocket chain tension.
- * Test pull-out forced of drive shaft.
- * Rate testing of springs in systems.
- * Calibrate a cantilever beam-type Apparatus to obtain a force/deflection relationship.

12-5 Automotive

- * Measure force of seat belt retractors.
- * Measure arm pressure of windshield wipers.
- * Measure flip force in mechanical snap action switches.
- * Test effort to operate hand tool.
- * Test forces required to move linkages and tension cables.
- * Measure force of odometer pull.
- * Test peel strength of vinyl insert bonded to body side moldings
- * Evaluate physical efforts (door, lock, hood, glove compartment, brake pedal, etc.).

12-6 Other Industries

- * Measure pedal depression force in aircraft.
- * Test hardness of gypsum wallboard.
- * Test keyboard and pedal contact force of organs and pianos.
- * Test force to remove cover tops of aerosol cans.
- * Measure trigger pulling forces on firearms, hand tools etc.
- * Test firmness of sausages in casings.
- * Test integrity of seals on blister packages and plastic bags.
- * Test pressure of surgical instruments (forceps, scissors).
- * Test fruit removal force and fruit firmness.
- * Measure force on spindles of photographic equipment